

ISBe 5.9L BS IV (Bosch Fuel System)

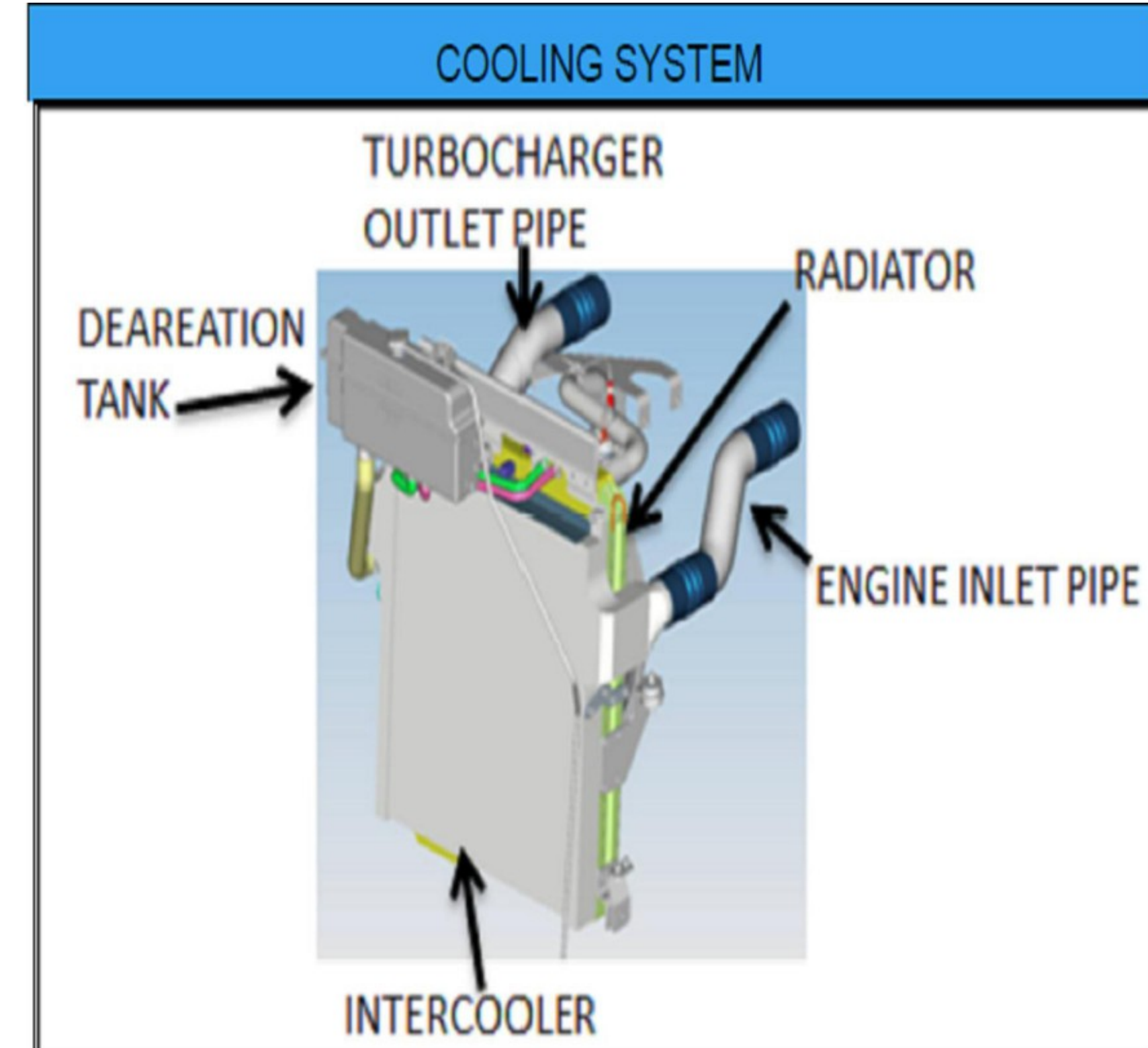
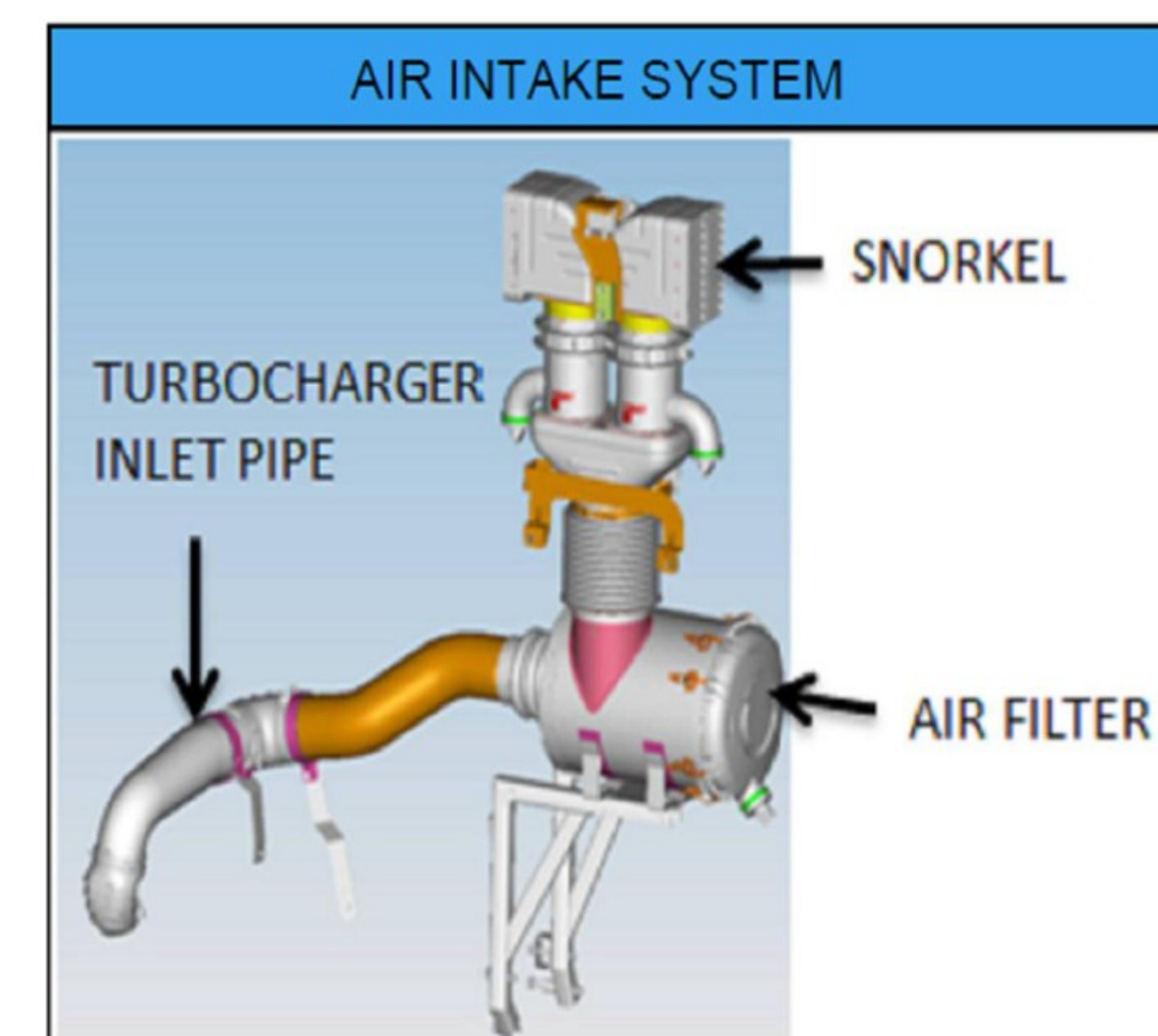
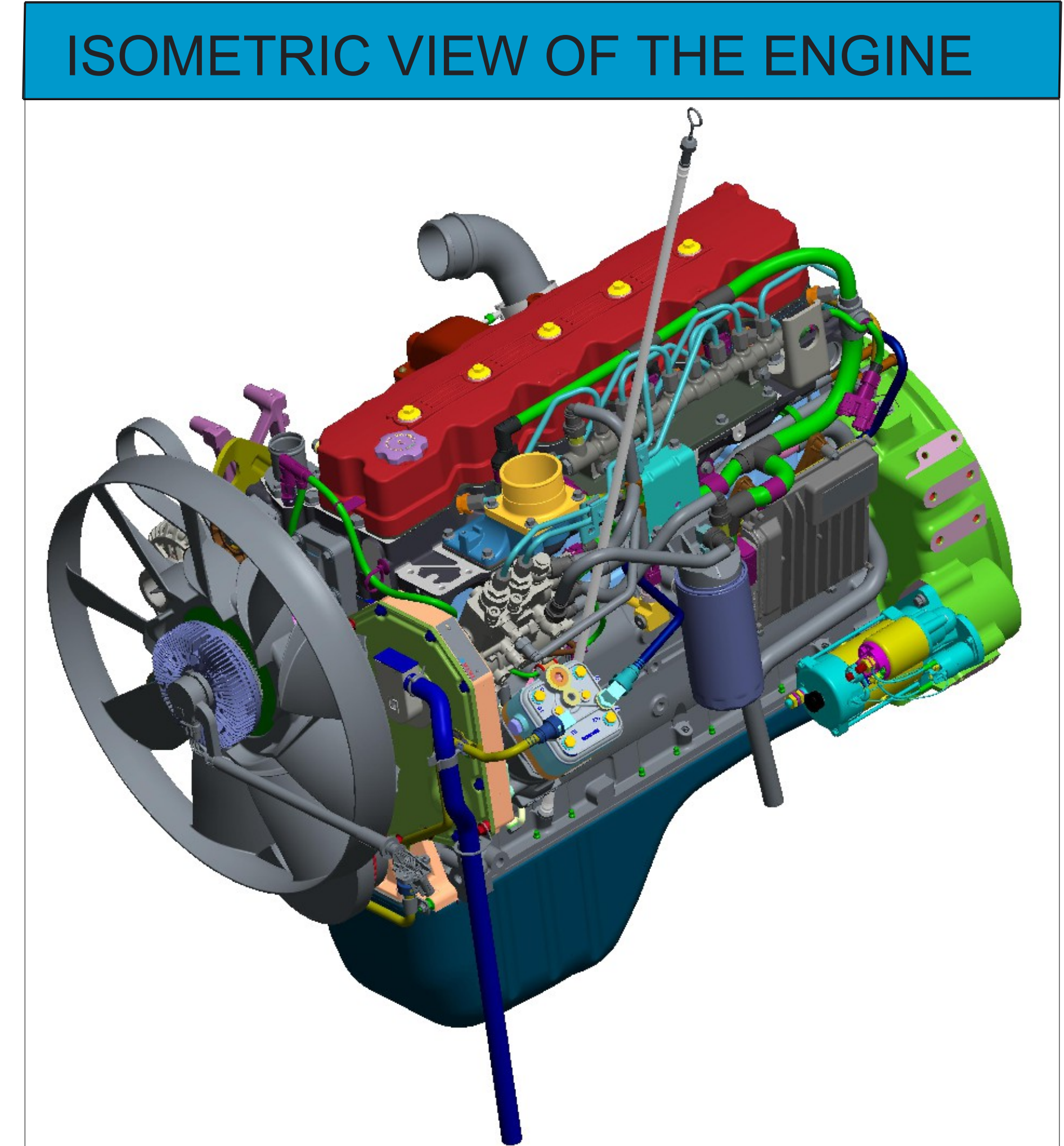
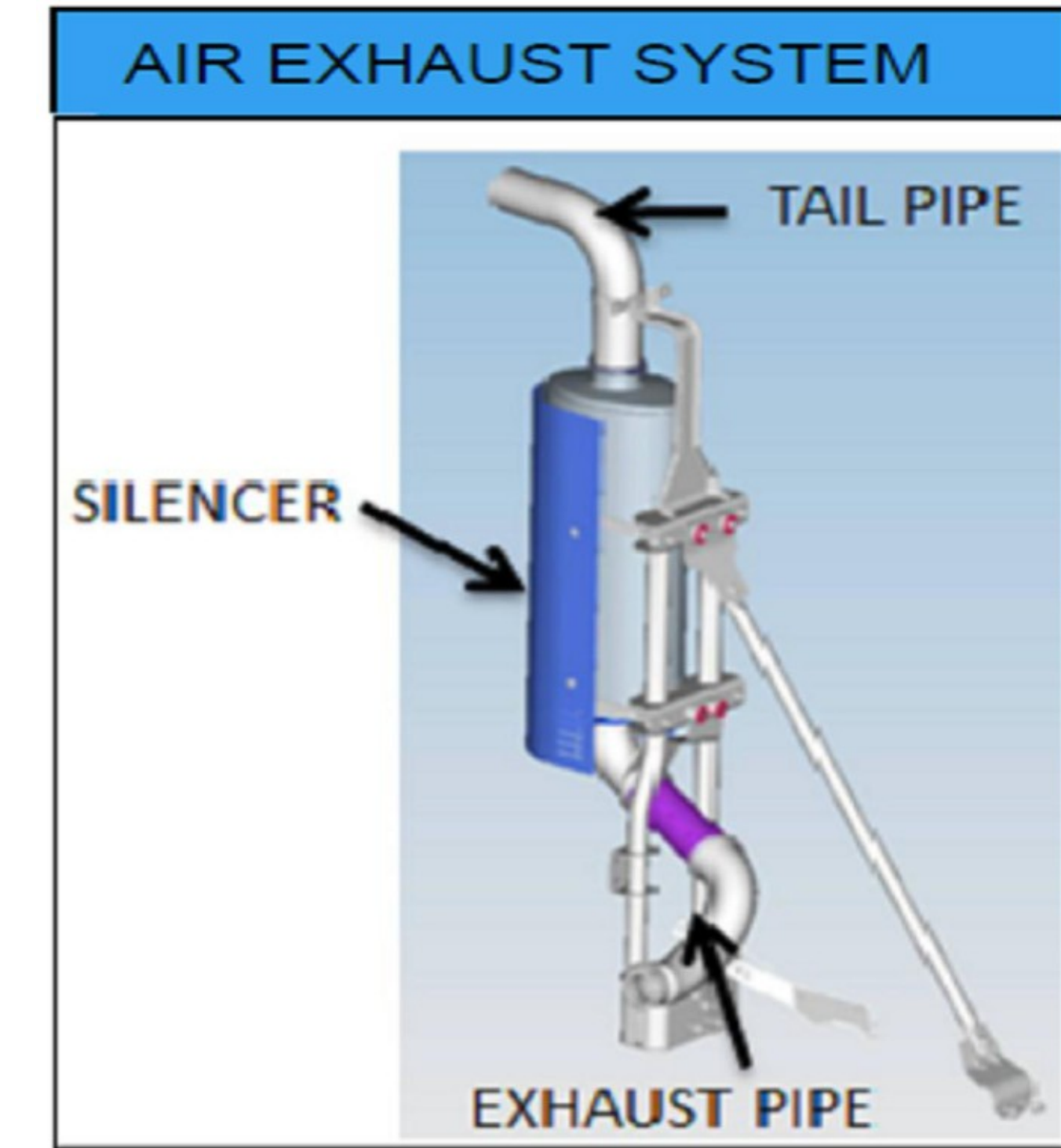
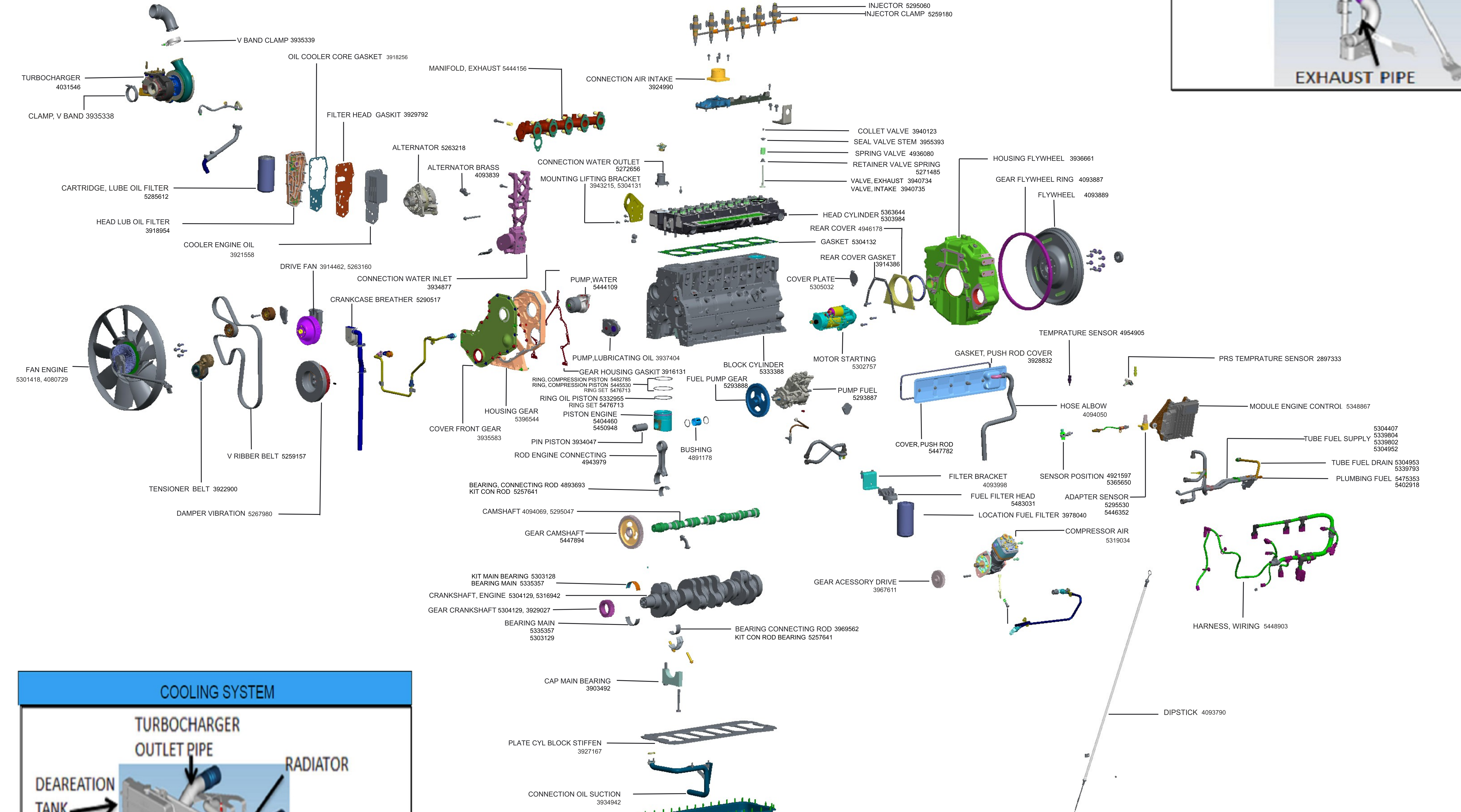
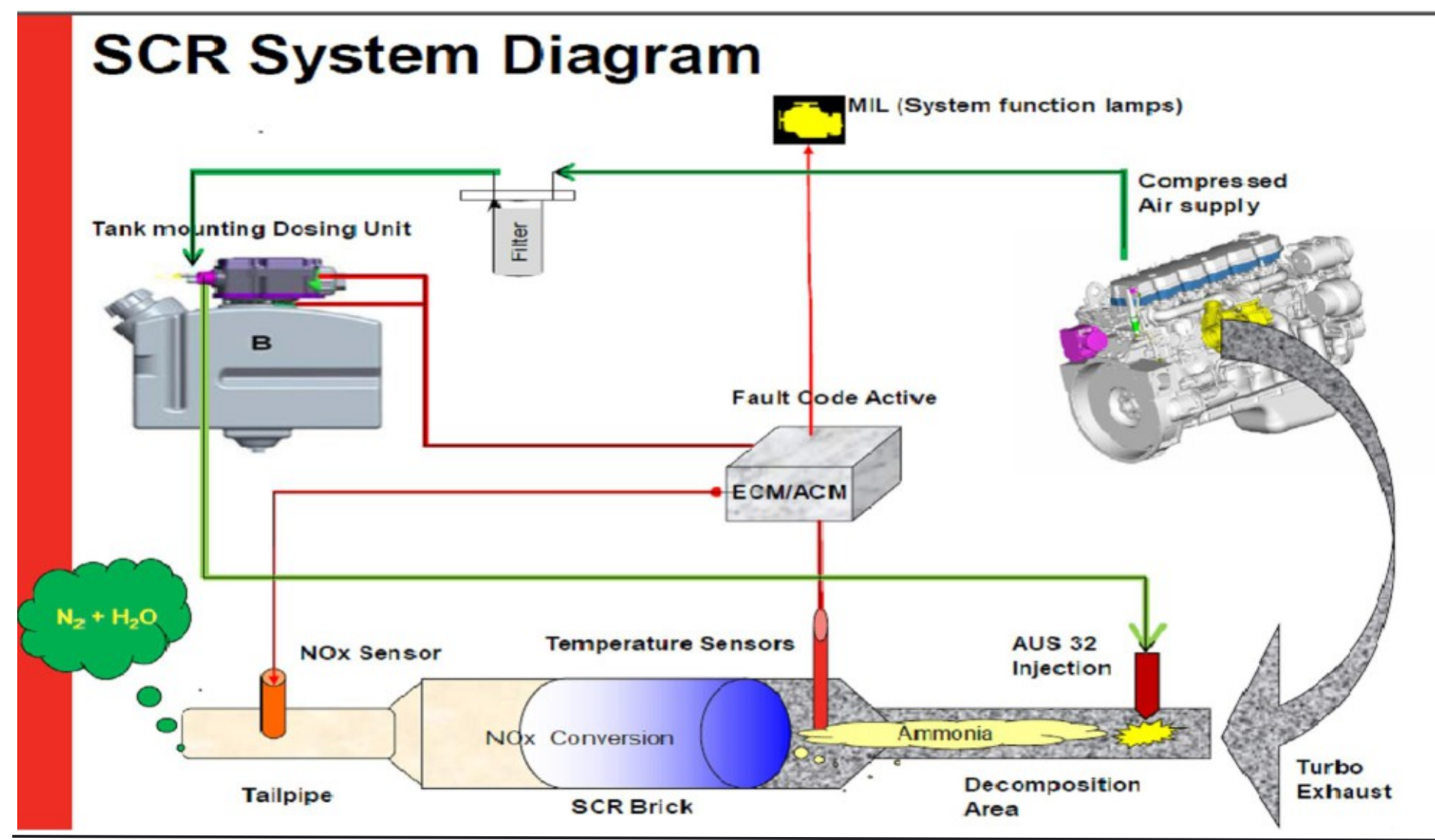

COOLANT SPECIFICATIONS

COOLANT:40/60-Ethylene glycol/water by volume
CAPACITY AND TEMPERATURES
Coolant capacity: 9.2L
Engine coolant temperature :100°C(MAX)
STANDARD THERMOSTAT RANGE
START TO OPEN : 83°C
FULLY OPEN :95°C

LUBRICATING OIL SPECIFICATIONS

LUBRICATING OIL DETAILS PREMIUM GRADE	
Oil grade : C14+	
Oil viscosity: 15W40	
Cummins INC> recommends the use of high quality SAE 10W40,15W40 & 10W30 heavy duty engine oil such as valvoline	
LUBRICATING SYSTEM PRESSURES AND TEMPERATURES	
Lubricating oil pressure at idle :90kPa	
Lubricating oil pressure at rated speed :300 kPa	
LUBRICATING OIL CAPACITY	
HIGH (STANDARD SUMP):20L	
LOW (STANDARD SUMP):12L	
TOTAL SYSTEM:22L	

Ask your Retailer for attractively priced kits, long blocks & other assemblies to get your vehicle back on the road faster!

Contact Cummins Toll Free Number: 1800-210-2525

Use your ESN for detailed view at parts.cummins.com. Scan the QR code to visit the website

